

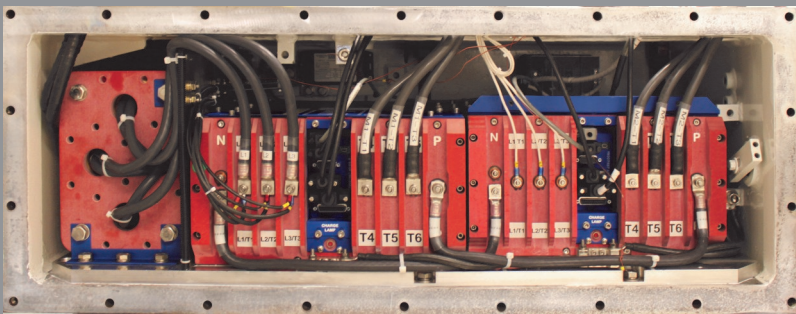

# SAMINCO

international



## JR1000 FAMILY OF 1000VAC VFD\* SYSTEMS

FOR UNDERGROUND MINING APPLICATIONS

\*VARIABLE FREQUENCY DRIVE

### 1000VAC TECHNOLOGY

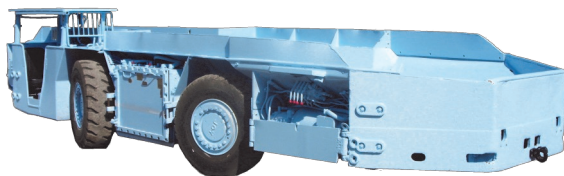

Shuttle Cars

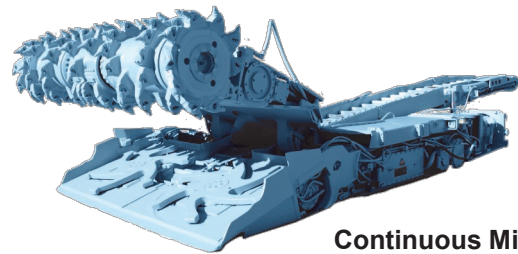

Continuous Miners

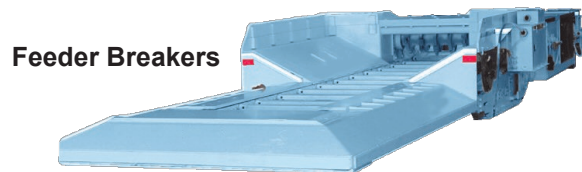

Feeder Breakers

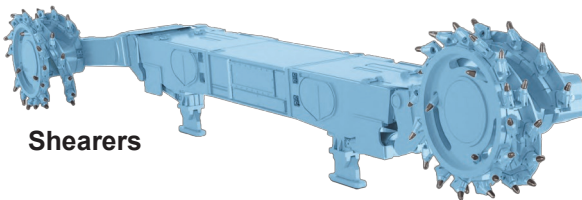

Shearers

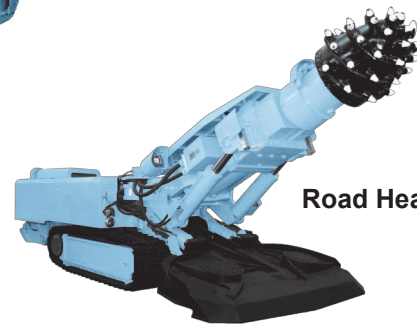

Road Headers

See videos of our products in operation at [www.samincoinc.com](http://www.samincoinc.com)

**Use this set-up for small continuous miners, small shuttle cars and feeder breakers.**

**A** VF1001 is configured as a single inverter to run a tram motor with encoder and as a rectifier receiving power from an AC trailing cable.

**B** VF1001 is configured as a dual inverter to run two motors independently; for example, a pump motor and a tram motor with encoder.

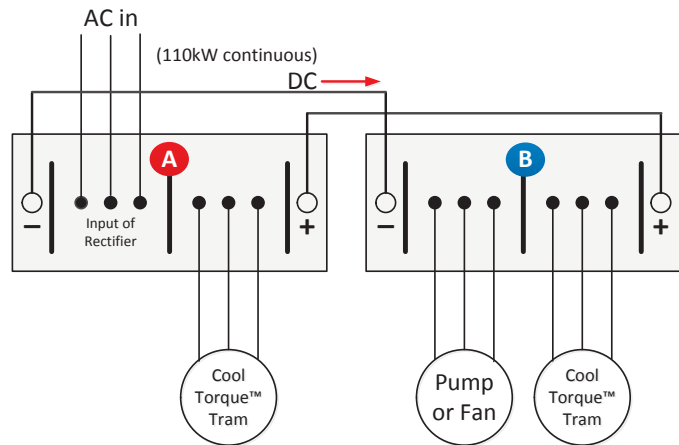

**Use this set up for feeder breaker with only the conveyor, or for only the fan (VFD Variable Speed Dust Collector System).**

**C** VF1001 is configured as a single inverter to run a conveyor motor and as a regenerative rectifier receiving power from an AC source.

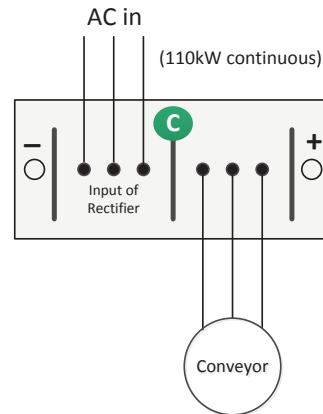

**Use this set-up for large continuous miners, large shuttle cars and feeder breakers.**

**D** VF1002 is configured as a regenerative rectifier.

**E** VF1001 is configured as a dual inverter to run a pump motor and a tram motor with encoder.

**F** VF1001 is configured as a dual inverter to run a conveyor motor and a tram motor with encoder.

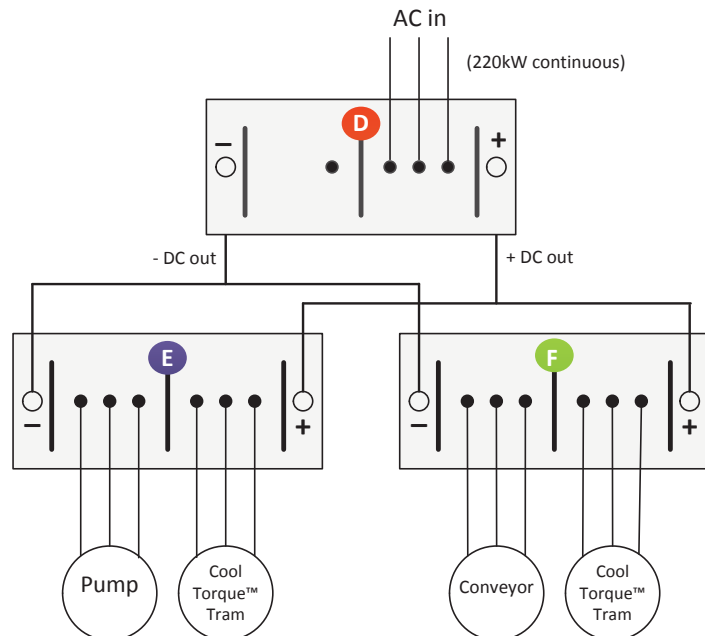

**THE VF1001: SINGLE INVERTER WITH REGENERATIVE INPUT OR DUAL INVERTER**



Saminco Part # A801001

Description	Inverter / Rectifier Application 1 Single Inverter with Regenerative Input 110kW / 1140V	Inverter / Inverter Application 2 Dual Inverter 110kW / 1140V
See page 2 for illustrations:	<b>A</b> <b>C</b>	<b>B</b> <b>E</b> <b>F</b>
<b>Example Applications</b>	Shuttle Cars, Continuous Miners, Shearers, Feeder Breakers	
<b>Electrical Specifications</b>		
Rated Power @ Rated Voltage	(for 1140VAC rms input) Input: 113kW Output: 110kW	(for 1500VDC input) Input: 180kW Output: 2 x 87kW
Voltage Range	Input: 855-1254VAC rms Output: 0-95% of input	Input: 1120 - 1773V DC Output: 0-70% of input (RMS AC)
Frequency Range	Input: 47-63 Hz, AC Output: 0-150 Hz	Input: DC Output: 0-150 Hz
Current @ Rated Power	Input: 83A AC rms Output: 85A AC rms	Input: 120A DC Output: 2 x 63A AC rms
<b>Physical Data</b>		
Length	483mm	483mm
Width	372mm	372mm
Height	202mm	202mm
Weight	55kg	55kg
<b>Thermal Data</b>		
Losses rejected to baseplate	2760W	2788W
Losses rejected to air	276W	279W

**THE VF1002: REGENERATIVE RECTIFIER OR INVERTER WITH DC INPUT**



Saminco Part # A801002

Description	Regenerative Rectifier Application 1 Regenerative Rectifier 220kW / 1140V	Regenerative Rectifier Application 2 Inverter with DC Input 220kW / 1140V
See page 2 for illustrations:	<b>D</b>	
<b>Example Applications</b>	Large shuttle cars, large continuous miners, feeder breakers, shearers	
<b>Electrical Specifications</b>		
Rated Power @ Rated Voltage	(for 1140VAC) Input: 223kW Output: 220kW	(for 1500VDC) Input: 223kW Output: 220kW
Voltage Range	Input: 855 - 1254V ACrms DC Output: 135% of AC	Input: 1150 - 1750VDC Output: 0-70% of DC input value
Frequency Range	Input: 47 - 63 Hz, AC Output: DC	Input: DC Output: 50/60 Hz
Current @ Rated Power	Input: 136A ACrms Output: 151A ACrms	Input: 150A Output: 151ACrms
<b>Physical Data</b>		
Length	314mm	314mm
Width	472mm	472mm
Height	215mm	215mm
Weight	65kg	65kg
<b>Thermal Data</b>		
Losses rejected to baseplate	3000W	3000W
Losses rejected to air	300W	300W

### ADVANTAGES OF THE SAMINCO FAMILY OF JR1000 VFD SYSTEMS

Designed for use in shuttle cars, continuous miners, shearers, road headers and feeder breakers. These drives can be custom configured to provide the torque and power requirements of your mining equipment.

- Voltage ranges of 850V to 1260V, 3PH 50/60 Hz available to accommodate most international customers.
- Multiple voltage outputs
- Smart rectifier modules provide energy-saving regenerative braking down to stall which can be held indefinitely without inverter or motor overheating.
- Systems can be designed for air contact-cooled or liquid cooled base plate
- Closed loop flux vector and open loop flux vector modes for unsurpassed accuracy to allow low speed holding when descending, especially when proximity detection system requested.
- Analog reference input and/ or CAN Bus Communications is available.
- Maximum output frequency of 150Hz
- Adaptive under voltage and overvoltage control
- Radio controlled option is available.
- Cutter motor feedback to optimize tram speed.
- Full motor protection (overload, short circuit, lock rotor, Motor RTD, online, jam, phase loss, ground fault).
- Our AC drive has up to 2X starting torque compared to a DC motor .
- Infinitely variable speed tramming.

### MODES OF CONTROL

**Saminco offers three modes of control.**

1. Vector control closed-loop: This is our main control(\*).
2. V/F: Mainly used for conveyor and fans.
3. Vector control open loop: Most common mode used in the industry, however, Saminco uses it only as an emergency backup in case of encoder failure (See \* below. Not recommended by Saminco as primary mode as our other control platforms out perform it.)

Drive type	DC	VFD AC	VFD AC	VFD AC
Control platform	Brush type DC	V/Hz control	Vector control	Vector control
Control Criteria	Close loop	Open- loop	Open-loop	Closed -loop
Motor	DC	IM	IM	IM
Typical speed Regulation (%)	0.01	1	0.5 *	0.01*
Typical speed range at constant torque (%)	0-100	10-100	3-100 *	0-100*
Min. speed at 100% torque (% of base)	Standstill	8%	2%*	Standstill*
Multiple-motor operation recommended	No	Yes	No	No
Fault protection (Fused only or inherent to drive)	(Drive) Fused only	Inherent	Inherent	Inherent
Maintenance	(Brushes)	Low	Low	Low
Feedback device	Tachometer encoder N/A	N/A	N/A	encoder

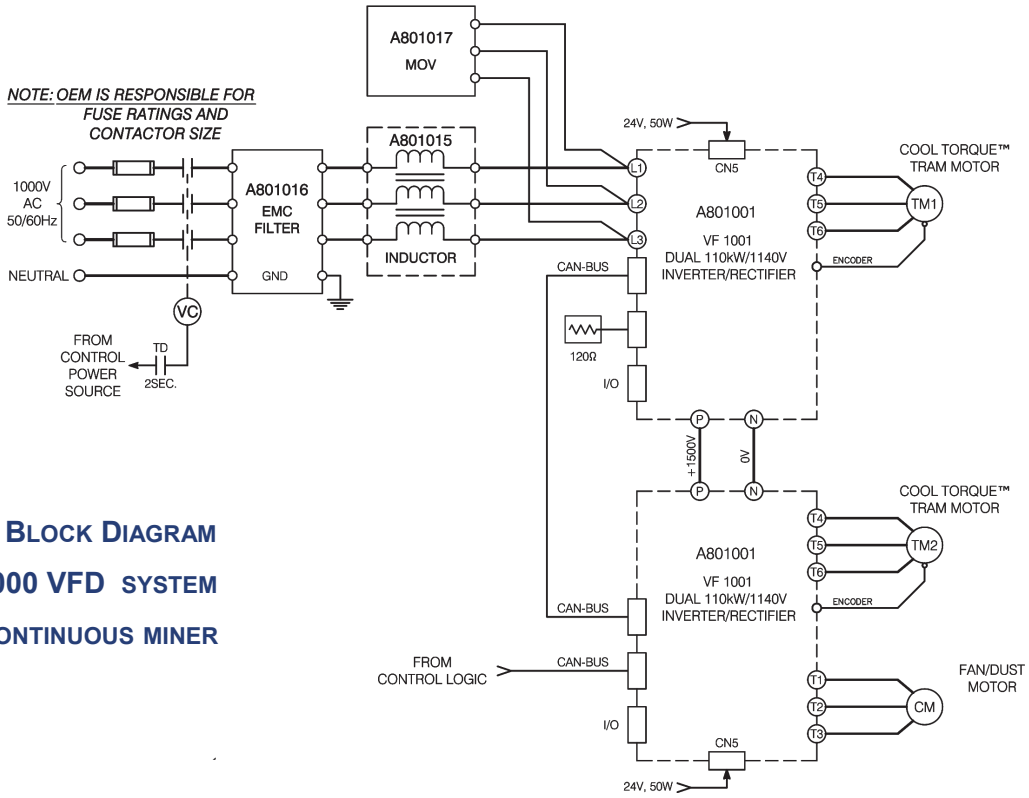

**SAMPLE BLOCK DIAGRAM OF JR1000 VFD SYSTEM FOR A CONTINUOUS MINER**

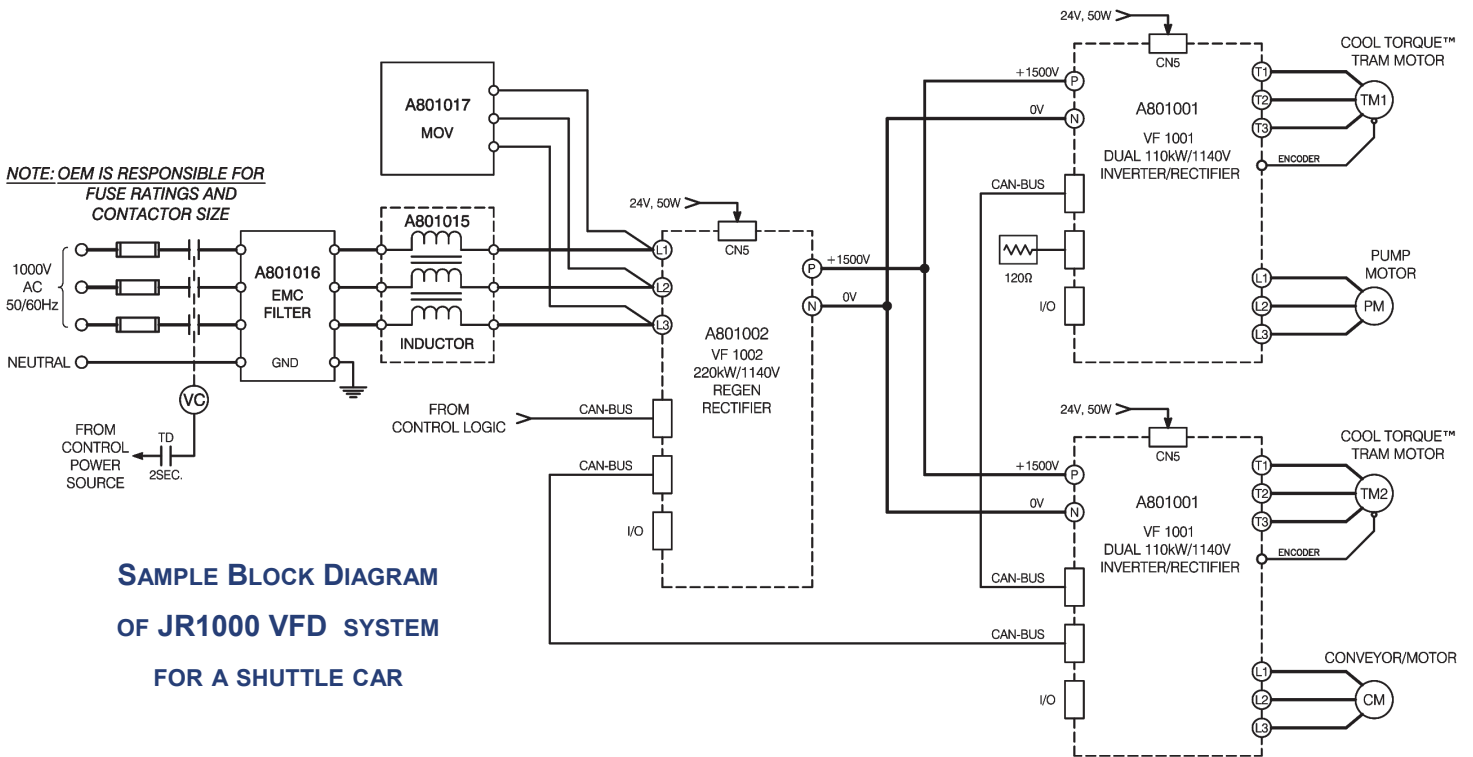

**SAMPLE BLOCK DIAGRAM OF JR1000 VFD SYSTEM FOR A SHUTTLE CAR**



## SAMINCO COOL-TORQUE™ MOTORS

(See separate brochure for more information)

Available for inverters with AC or DC inputs of 120VDC to 500VDC or 230VAC / 1000VAC

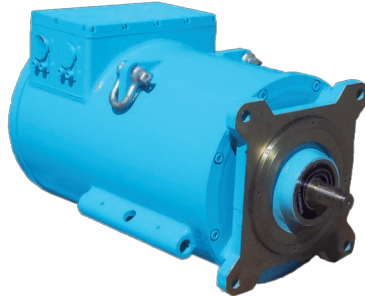

**Air-Cooled**

Model: TM1000 with 1000Nm stall torque

## MSHA CERTIFIED

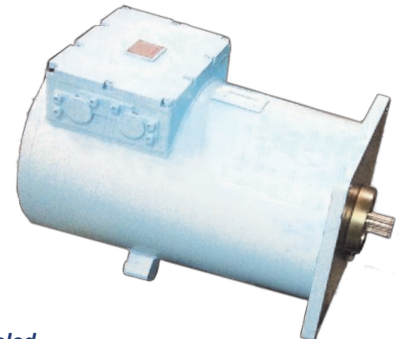

**Water-Cooled**

Model: TM1200 with 1200Nm stall torque

- Saminco TM1200 (CM traction) and TM1000 (SC traction) torque motor replace the original OEM's motor without any mounting modifications
- Absence of brushes greatly reduces motor maintenance
- Internal Encoder on motor gives **Closed Loop Control** down to zero speed. This gives full control of machine to slow, creep and hold on any mining grade. Energy saving full regenerative braking allows slowing and stopping of the machine indefinitely without inverter or motor overheating.
- Machine Runs cool - no water cooling required during extended tramming for place changes. **Low Current draw of motor (Low AMPS) = extended LIFE.**
- Torque and speed-sharing between motors with greater starting torque.
- Proximity detection system ready for reliable stopping and creep speed control.

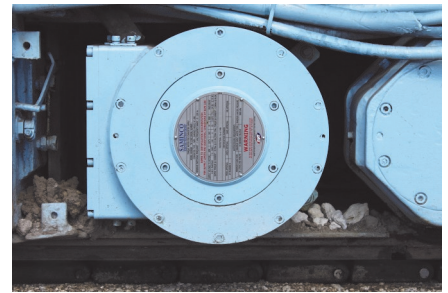

## OPTIONAL ADD-ONS

### VFD Variable Speed Dust Collector System

The variable speed dust collector system reduces the number of fan combinations needed and conforms with AMS with the adjustable positions.

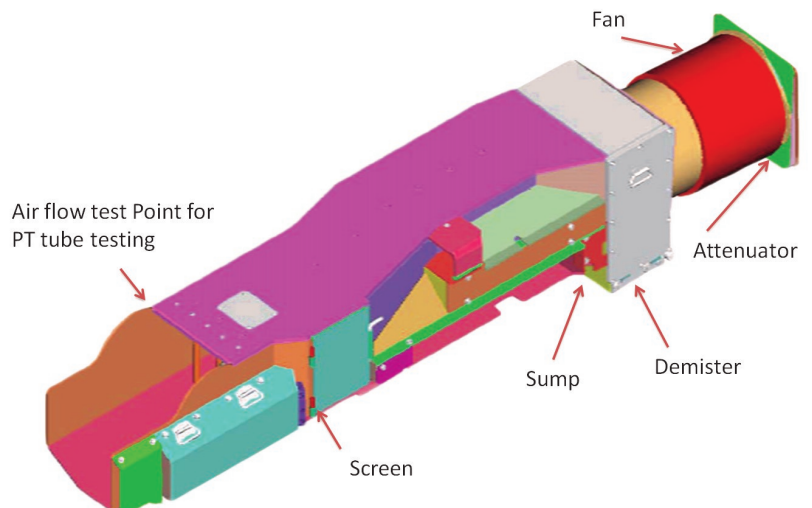
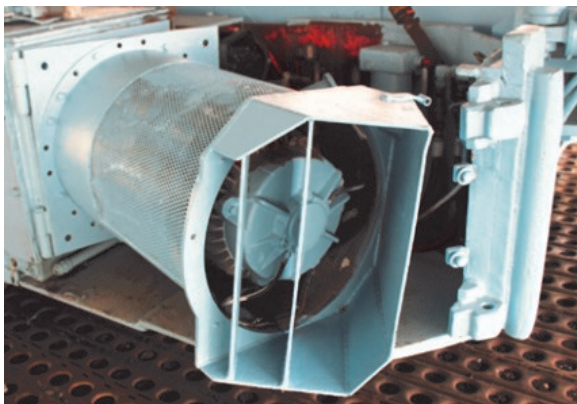

**CONTROL SYSTEM**

The control system interfaces to existing componentry systems including all hydraulics and other related controls. The controller package is located in the XP box and is hard wired to an external antennae. It is controlled via a wireless handheld radio transceiver. Upgrades to firmware are as simple as attaching a USB drive loaded with the firmware to the USB port on the controller package inside the XP box. USB download capable.

**Handheld radio transceiver with data storage capability** Part # A700109



*View of transceiver on docking station*  
Part # A700107



**Antenna** Part # A700118



Antenna is hard wired to controller inside the XP box.

**Specifications:**  
Height 138mm (5.45")  
Maximum power: 2 Watts  
Mounting base: 3/4" NPT

**MSHA APPROVED #18-A160002-0**

*Not shown are the Vehicle Controller System, CAN Receiver and Relay Receiver.*

**GRAPHIC DISPLAY**

**Display** Part # A800810

On-board video displays showing machine functions and operations, including data logging for maintenance and troubleshooting.

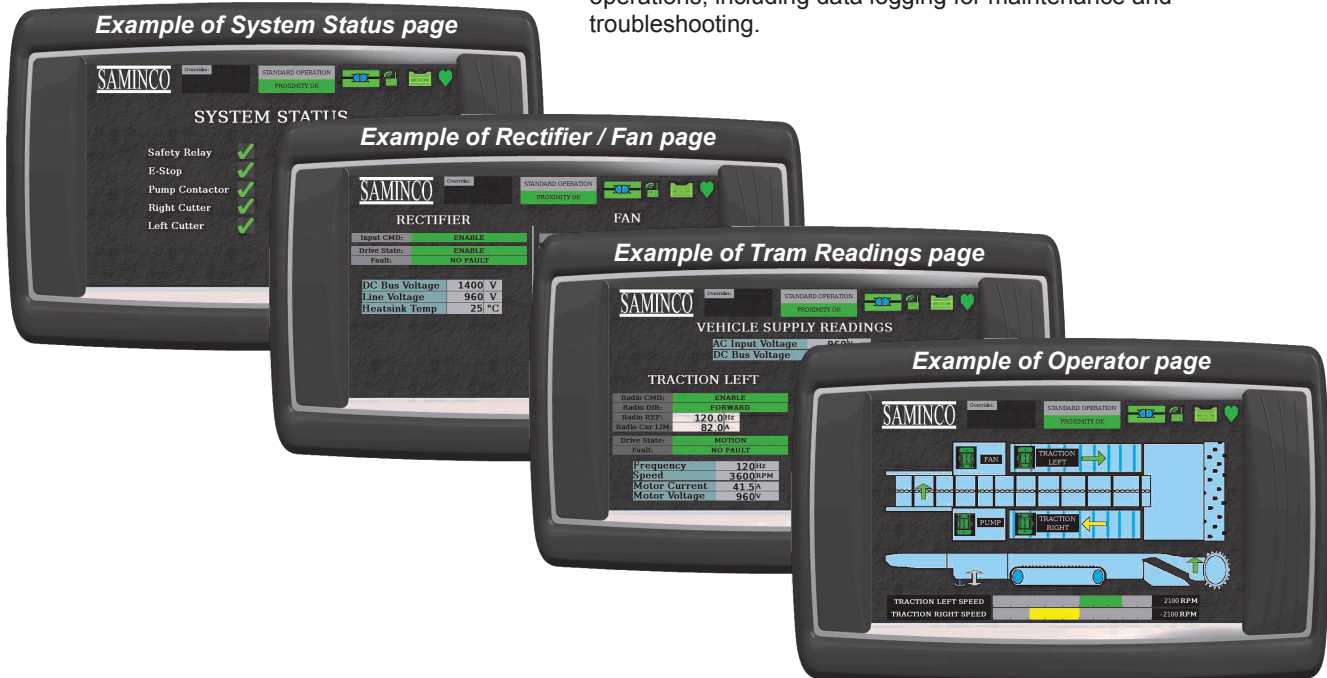

**OPTIONS\* FOR THE  
JR1000 VFD SYSTEM**

Part Name	Description	SAMINCO Part Number
VF1001 Inverter	Single Inverter with Regen Input or Dual Inverter	A801001-1
VF1002 Regen Rectifier	Regen Rectifier or Inverter with DC Input	A801002
Inductor	0.36mH / 150A 3PH 1200V	A801015
EMC Filter	1260VAC 120A 50/60Hz	A801016
MOV-Varistor	3PH 1200V 1500Joule	A801017
Graphic Display	Digital Display	A800810
Fan Control	VFD Scrubber Fan - Fan Speed Switch Assembly	A801054
Handheld Programmer	Universal Drive Programmer	A800220-1
Mini Heat Spreader	VFD Scrubber Fan - Mini Heat Spreader	Y9005404A
Cable	Cable 25CON SUB-D 72	W6004-004
Cable Assembly	Cable Assembly 15 PIN 36"	W6004-356
Cable Kit	Cable Kit for continuous miner	W6100035
Wire Harness	SAMCAN Wire Harness	W6100037
<b>TC3-LHD Radio Remote Control</b>		
TC3-LHD Remote Control	Radio remote control	A700109
TC3-LHD Charger	With power cord	A700108
TC3-LHD Docking Station	Docking Station	A700107
TC3 Can Receiver	CanBus Proximity - Radio RVU	A700110
TC3 Relay Receiver	RVU AGS Ready	A700114
Controller	Vehicle Control System	A801052
Antenna	900MHz mine duty	A700118
<b>Motors and Encoders</b>		
TM1200 Cool-Torque Motor	1200Nm 950VAC 3PH (TM1200 Cool Torque for CM-water cooled)	M6005-037
TM1000 Cool-Torque Motor	1000Nm 55kW 1193VAC XP (TM1000 Cool Torque for SC-air cooled)	M6005-034
Pump Motor	18kW 3Phase 60Hz 80 -138V AC	M6005-019
Motor Encoder Assembly	Contains encoder and wheel	M6006-020
Encoder Backplate	Universal backplate	M6006-022
Encoder	Encoder sensor	M6006-023

\*Partial list shown. See your sales representative for all available options and configurations.



*Feeder Breaker Controller installation*

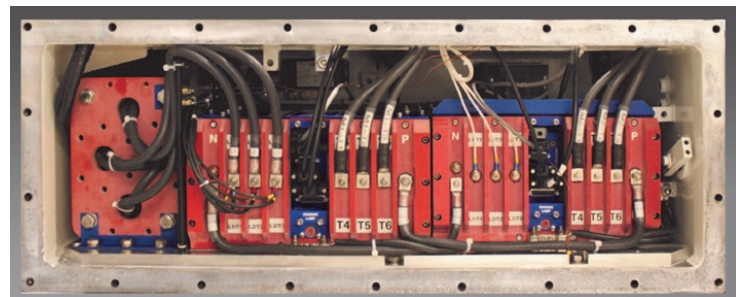

*14CM Continuous Miner installation*

Visit our website at [www.samincoinc.com](http://www.samincoinc.com) or email us at [sales@samincoinc.com](mailto:sales@samincoinc.com)



**FLORIDA**  
*Headquarters*  
10030 Amberwood Rd.  
Fort Myers, FL 33913  
PH: 239-561-1561  
FAX: 239-561-1502

**WEST VIRGINIA**  
*Service Branch*  
517 Virginia Ave.  
Huntington, WV 25701  
PH: 304-523-4700  
FAX: 304-523-4039

**COLORADO**  
*Service Branch*  
Cedaredge, CO  
PH: 940-623-0000

**SOUTH CAROLINA**  
*Service Branch*  
Anderson, SC  
PH: 304-654-9054

**INTERNATIONAL LOCATIONS:**  
Boksburg, South Africa PH: +27 011 397 6026  
Australia PH: +61 2 9899 6857  
China PH: +86 15140090694  
Poland